



T 144 H PLUS



TECHNICAL DATA

		T 144 H PLUS M352 / M352+A35200039
GENERAL		
Load capacity	Kg	1350
Load capacity at maximum height	Kg	770
Maximum height	mm	3990
Maximum height under maximum load	mm	3490
Maximum reach	mm	1682
Maximum load at maximum reach	Kg	580
Unladen weight *	Kg	2400
Transmission		Hydrostatic automatic control
ENGINE		
Make		KUBOTA
Model		V-1505
Power	kW	22,7 / 18,5 **
Torque	Nm@rpm	93,9@1700
No. cylinders		4
Emissions		Tier4i - Stage IIIA / Tier4f
Ambient noise	dB(A)	103
Consumption	l/h	5,9 / -
CO2	Kg/h	15 / -
DRIVING		
Maximum speed	Km/h	17
Gradeability under full load	%	26
Traction		4x4
Front tyres		11.0/65x12
Rear tyres		11.0/65x12
HYDRAULIC SYSTEM		
Flow rate	l/min	19
Working pressure	bar	240
TANK CAPACITY		
Fuel	l	55
Hydraulic	l	32
FRENOS		
Service		Hydrostatic - retention
Parking		Mechanically applied hydraulically released inside the hydrostatic motor

* It may change due to optional equipment ** Optional engine

DIMENSIONS

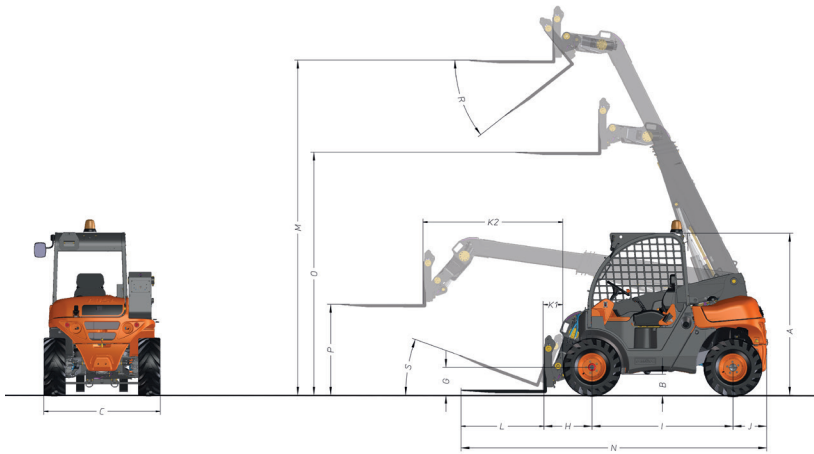

AUSA carriage

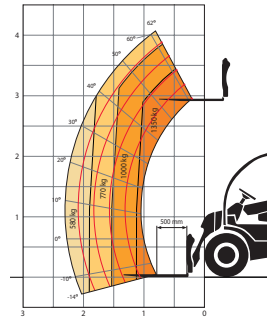

Universal & EURO8 carriage

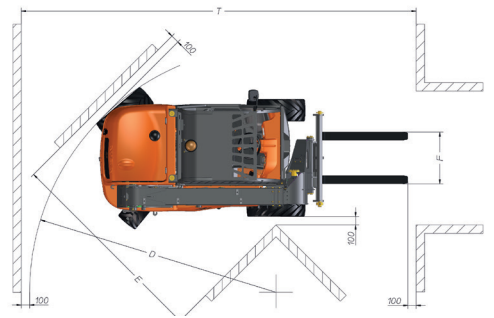
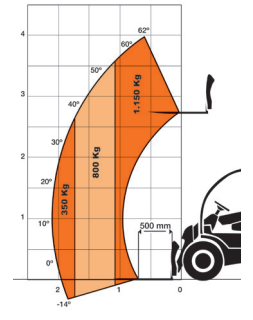

DIMENSIONS (mm)

T 144 H PLUS

A	1950
B	252
C	1405
D	2982
E	2481
F	1015
G	335
H	580
I	1700
J	405
K1	228
K2	1682
L	1000
M	4036
N	3685
O	2928
P	1094
R	38°
S	20°
T	4730



www.ausa.com

Products are subject to modifications without prior notice. Images throughout the spec sheet may refer to non-standard machines or non-available configurations depending on models.

AUSA's logo and corporate identity are property of the Company, they cannot be used without authorization.